

Complies with the machinery directives 2006/42/EC

4 better
lifting



CE



NB: Please ensure that the safety instructions have been fully read and understood before initial use of the hoist ring for bolting VWBG. Failure to do so may result in serious injuries and/or material damage and eliminates manufacturers warranty.

User Instructions - Part 1

Safety instructions

This safety instruction/declaration of the manufacturer must be kept on file for the lifetime of the product.

ATTENTION: Please inspect all components prior to use. Damaged, incorrect assembly or improper use may result in serious injuries and/or material damage.

EC-Declaration of the manufacturer

According to the Machinery Directive 2006/42/EC, annex II B and amendments.

We hereby declare that the design and construction of the equipment detailed within this document, adheres to the appropriate level of health and safety of the corresponding EC regulation.

Any un-authorized modification and/or any incorrect use of the equipment not adhered to within these user instructions waives this declaration invalid.

The equipment must be regularly tested and inspected as per BGR 500. Failure to carry out the recommended maintenance and testing waives this declaration invalid.

Designation of the equipment:

Type: **Hoist Ring for Bolting Vario VWBG**

Manufacturer's mark:

Drawings (iges, dxf and step), product information and other support material can be downloaded from www.rud.com.au.

EC-Declaration of conformity

According to the EC-Machinery Directive 2006/42/EC, annex II A and amendments

Manufacturer: **RUD Ketten
Rieger & Dietz GmbH u. Co. KG
Friedensinsel
73432 Aalen**

We hereby declare that the equipment sold by us because of its design and construction, as mentioned below, corresponds to the appropriate, basic requirements of safety and health of the corresponding EC-Machinery Directive 2006/42/EC as well as to the below mentioned harmonized and national norms as well as technical specifications. In case of any modification of the equipment, not being agreed upon with us, this declaration becomes invalid.

Product name: Load ring
VWBG-V / VWBG

The following harmonized norms were applied:

<u>EN 12100 : 2011-03</u>	<u>EN 1677-1 : 2009-03</u>
<u>EN 1677-4 : 2009-03</u>	
_____	_____
_____	_____

The following national norms and technical specifications were applied:

<u>BGR 500, KAP2.8 : 2008-04</u>	_____
_____	_____
_____	_____
_____	_____

Authorized person for the configuration of the declaration documents:
Reinhard Smetz, RUD Ketten, 73432 Aalen

Aalen, den 27.06.2014 Dr.-Ing. Arne Kriegsmann (Prokurist/OMB)
Name, function and signature of the responsible person

User Instructions - Part 2

1. Safety Instructions



ATTENTION: Please inspect all lifting points prior to use. Damage, incorrect assembly or improper use may result in serious injuries and/or material damage.

- Not suitable for permanent turning operations under load. Lifting point cannot be turned to 90° from the bolt-on direction under full load.
- The ball bearing must not be disassembled.
- The load ring must not be free to articulate.
- RUD VWBG lifting points must only be used by instructed and competent persons considering BGR 500 / DGUV 100-500 and outside Germany noticing the country specific statutory regulations.

2. Intended use of VWBG

RUD VWBG lifting points must only be used for the assembly at the load or at lifting means.

They are intended to be bolted into the payload and can be turned under load, but not under full load, especially not in the 90° direction. Not suitable for permanent turning operations under load.

RUD VWBG lifting points can also be used as lashing points to attach lashing means.

If the lifting points are used exclusively for lashing the value of the WLL (working load limit) can be doubled. LC (lashing capacity) = 2 x WLL.

RUD VWGB-V lifting points must only be used in the hereby described operation purpose.

Before installing and every use, visually inspect RUD lifting points, with particular attention to any evidence of corrosion, wear and weld cracks and deformations. Please ensure compatibility of bolt thread and tapped hole.

3. Assembly and Instruction Manual

3.1 General Information

- Temperature range:
Usage at higher temperatures is not recommended due to the grease filling in the ball bearing. Should this though be necessary, the working load limit (WLL) of the VWBG must be reduced as follows:

-40°C up to 100°C	no reduction
100°C up to 200°C	minus 15 %
200°C up to 250°C	minus 20 %
250°C up to 350°C	minus 25 %

Temperatures exceeding 350°C are prohibited!

Please pay attention when using DIN EN 7042 (DIN 980) nuts the max. operation temperature of 150°C (acc. to DIN EN ISO 2320).

- RUD VWBG lifting points must not be used with aggressive chemicals such as acids, alkaline solutions and their vapours.

3.2 Hints for the assembly

- The material construction to which the lifting point will be attached should be of adequate strength to withstand forces during lifting without deformation.

The German testing authority BG, recommends the following minimum for the bolt lengths:

1.0 x M in steel (minimum quality S235JR [1.0037]) ≈ AS3678 GR250.

1.25 x M (thread diameter) in cast iron (e.g. GG 25)

2 x M (thread diameter) in aluminium

2.5 x M (thread diameter) in light alloys of low strength (M = thread size/diameter, e.g. M20)

- When lifting light metals, nonferrous metals and gray cast iron the thread has to be chosen in such a way that the WLL of the thread corresponds to the requirements of the base material.
- The min. quality of the hexagon bolt of the VWBG must be class 10.9 according to EN 24014 (DIN 931) with correct nominal diameter.
- RUD supplies the Vario length complete with a washer and crack-detected nut corresponding to DIN EN ISO 7042 (DIN 980) or will be supplied with a crack inspected collar nut acc. to DIN 6331 or 2 x crack inspected hex nuts Class 8 AS1112.1 with washer.
- The position of the lifting points must be carried out in such a way that unintended movement like turning or flipping will be avoided.
 - For single leg lifts, the lifting point should be vertically above the centre of gravity of the load.
 - For two leg lifts, the lifting points must be equidistant to/ or above the centre of gravity of the load.
 - For three and four leg lifts, the lifting points should be arranged symmetrical around the centre of the gravity, in the same plane if possible.

Load Symmetry: The working load limit of individual RUD lifting points are calculated using the following formula and are based on symmetrical loading:

$$W_{LL} = \frac{G}{n \times \cos \beta}$$

WLL = required of lifting point/individual leg (kg)
 G = load weight (kg)
 n = number of load bearing legs
 β = angle of inclination of the individual leg

NOTE: For WLL Calculations

- β angle is taken from the vertical plane.
- Included angle is the angle between the sling legs.



Number of load bearing legs is as follows:

	Symmetrical	Unsymmetrical
2/3/4 leg	2	1

Load bearing legs (compare also with table 1)

- When lifting points are used in a multileg assembly, care should be taken to calculate the WLL (Working Load Limit) due to the deration caused by forces acting in multiple directions. The reduction in WLL (Working Load Limit) for multileg assemblies should be checked with relevant Standards e.g. AS 3775.2:2014 Chain slings for lifting purposes - Grade T(80) and V(100) - Care and use.
- The lifting points should be mounted in such a way that they may easily be accessed for inspection and assembly/disassembly of the sling.

User Instructions - Part 2

- A plane bolting surface must be guaranteed to ensure correct mating of the lift component. The thread must be carried out acc. to DIN 76 (countersink max. 1.05xd).
- Tapped holes must be machined deep enough so that the bearing surface of the lifting point will be supported. Machine through holes up to DIN EN 20273-middle.
- For single use just tighten with spanner. For long term application and when turning loads the VWBG should be tightened to torque according to relevant table (+/- 10%). In case of turning movements (continuous operation) the recommended torques have to be checked regularly.
- The type VWBG can be supplied with different thread lengths (see Fvario in table 2), and the metric versions with washer and crack detected nut.



ATTENTION: Check the correct assembly (see chapter 4, Inspection Criteria).

3.3 User Instructions

- Check frequently and before each initial operation the whole lifting mean for corrosion, wear, deformation etc. (see chapter 4, Inspection criteria).



ATTENTION: Incorrectly assembled or damaged lifting points, as well as improper use can lead to injuries to persons and plant damage. Please inspect all lifting points before each use.

- VWBGs are suitable for turning and flipping of loads. In doing so, all positions of the ring can occur. The stated WLL at the lifting point is given for the most inappropriate possible case of operation (see picture 5 - part X). When ring has been adjusted manually (see picture Y) the higher (WLL) values from table 3 can be used.



ATTENTION: Pay attention during the usage that the load type will not be changed.

If the VWBG is to be loaded only perpendicular (in axial direction of the thread, see picture 3 - part Z) the corresponding WLL values from table 3 (inclination angle 0°) can be used.

- The ring of the manually adjusted VWBG can be pivoted by approx. 230° (see picture 1).

ca. 230°

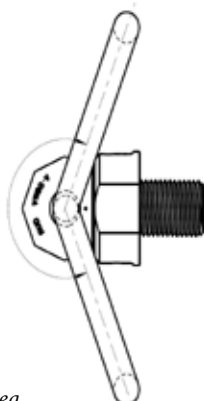

Pic. 1: Pivoting area



ATTENTION: The lifting ring must rotate and pivot without interference during lifting (see picture 2).

- When lifting means (sling chains) are hinged or unhinged, no pinching, shearing or joint spots must occur during the handling. Avoid damage of lifting means resulting from sharp edges.
- Distance yourself from the direct danger zone.
- Always watch the load during the lift.
- Avoid sudden or shock loading.



ATTENTION: Loading or vibration can lead to unintentional loosening.

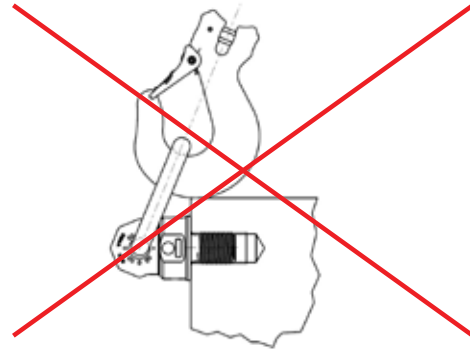

Pic. 2: Forbidden contact or support at/or with edge

- To prevent unintentional dismounting through shock loading, rotation or vibration thread locking fluid such as Loctite (depending on the application, please refer to the manufacturer's instruction) should be used to secure the bolt.

3.4 Hints for regular inspection

After fitting, an annual inspection (or sooner if conditions dictate) should be carried out by a competent person examining for continued suitability. Also inspect after damage and special occurrence.

User Instructions - Part 2

4 Inspection criteria

Observe and control the following points before each initial operation at regular time intervals, after the assembly and after special incidents:

- Correct bolt- and nut size plus thread engagement.
- Inspection of bolting torque.
- The bearing surface of the VWBG must be plane.
- Completeness of the lifting point.
- Complete readable WLL markings and manufacturer sign.
- Deformation at load bearing components e.g. base body, load ring and threaded bolt.
- Mechanical damage, like notches, especially in areas where tensile stress occurs.
- Locking screw at the side must be tightened.
- Reduction of cross-section due to wear >10 % or when the wear marks have been reached in the main load bearing directions.
- Cracks or any other damage.
- Function and damage of bolt threads and nuts.
- Smooth rotation between upper and base part of the VWBG must be guaranteed.
- The maximum allowance for clearance of $s = 4$ mm, between upper and base part must not be exceeded, respectively the proof groove in the ring connection must not be visible.

5 Hints for the Repairing

Repair work must only be carried out by a competent person at RUD or by a RUD trained and authorised service station, which has obtained the necessary knowledge and skills.

RUD-VWBG's are designed for a dynamical loading of 20.000 load cycles at nominal working load. The BG recommends: At a high dynamic loading with high numbers of load cycles (continuous work) the bearing stress acc. to FEM group 1Bm (M3 acc. to DIN 818-7) must be reduced.

Example to investigate the required thread length F vario:

Plate thickness 50 mm, through hole for M 20 bolt, height of nut 20 mm, thickness of the washer 3mm, plus bolt projection 5 mm (2x pitch).

Order length: VWBG-2.0 M 20 x 78.

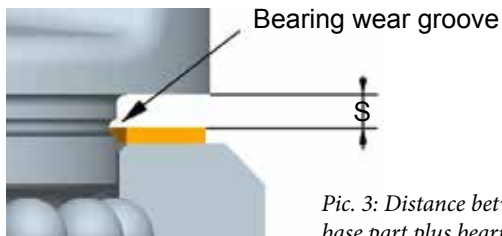

Pic. 3: Distance between upper and base part plus bearing wear groove

User Instructions - Part 3

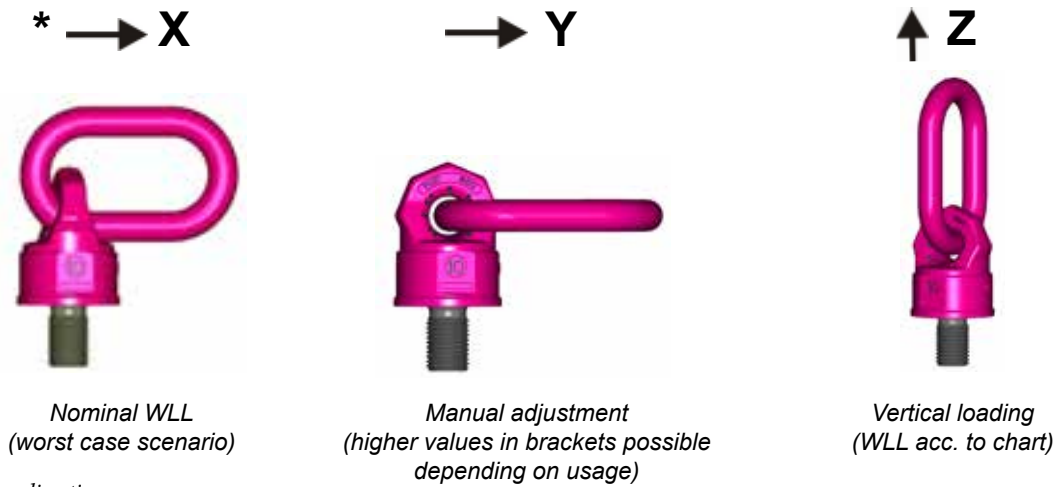

Pic. 4: Loading directions

Method of lifting									
Number of Legs			1	2	1	2			
Load Direction			0°	90°	90°	90°	2 leg @ 60°	2 leg @ 90°	2 leg @ 120°
Type	Thread Metric	Thread Imperial							
VWBG 6 (7.5)	M33	-	15	30	6 (7.5)	12 (15)	10.4 (13)	8.5 (10.6)	6 (7.5)
VWBG 8 (10)	M36	1 1/2"	15	30	8 (10)	16 (20)	13.8 (17.3)	11.3 (14.1)	8 (10)
VWBG 12 (13)	M42	1 3/4" - 1 7/8"	17	34	12 (13)	24 (26)	20.8 (22.5)	16.9 (18.3)	12 (13)
VWBG 12 (15)	M45	-	18	36	12 (15)	24 (30)	20.8 (26.0)	16.9 (21.2)	12 (15)
VWBG 13 (16)	M48	2"	18	36	13 (16)	26 (32)	22.5 (27.7)	18.3 (22.6)	13 (16)
VWBG 14 (20)	M52	-	25	50	14 (20)	28 (40)	24.2 (34.6)	19.7 (28.2)	14 (20)
VWBG 16 (22)	M56	2 1/4" - 2 1/2"	28	56	16 (22)	32 (44)	27.7 (38.1)	22.6 (31.0)	16 (22)
VWBG 16 (25)	M64	2 3/4" - 3"	28	56	16 (25)	32 (50)	27.7 (43.3)	22.6 (35.2)	16 (25)
VWBG 31.5 (40)	M72	3"	50	100	31.5 (40)	63 (80)	54.5 (69.2)	44.4 (56.4)	31.5 (40)
VWBG 35 (48)	M80	3 1/2"	50	100	35 (48)	70 (96)	60.6 (83.0)	49.3 (67.7)	35 (48)
VWBG 40 (50)	M90	4" - 5"	50	100	40 (50)	80 (100)	69.2 (86.5)	56.4 (70.5)	40 (50)

Table 1: WLL-overview VWBG



NOTE: The VWBG is designed to rotate and turn the load. Therefore the lifting point can engage in any position. The WLL is stated for the worst case situation in which the load direction may occur (see picture X). The ring can be manually adjusted to the direction of pull (see picture Y). Then the values in the brackets can be used.

User Instructions - Part 3

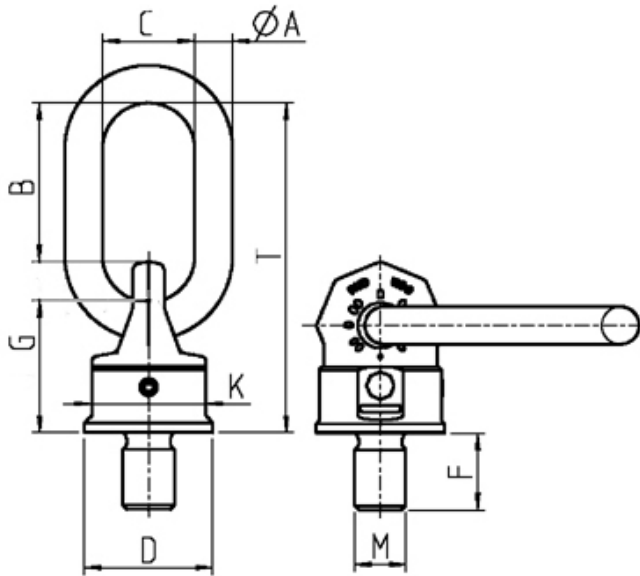

Pic. 5: Dimensioning VWBG (metric)

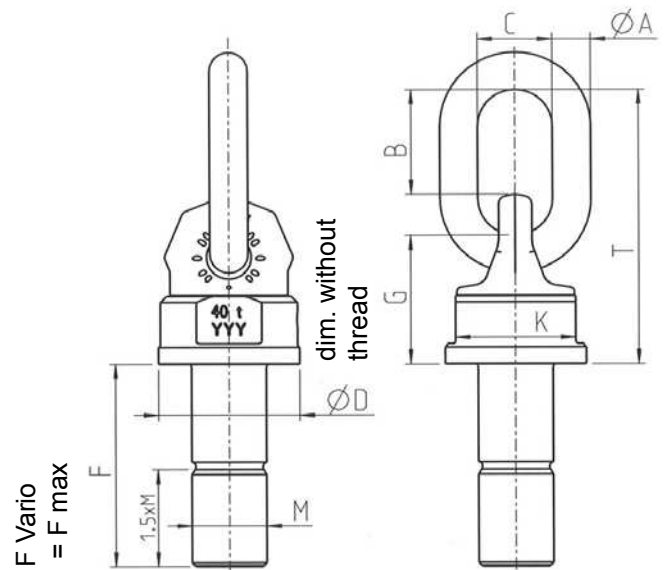

Pic. 6: Dimensioning VWBG

Type	WLL [t]	A [mm]	B [mm]	C [mm]	D [mm]	F stand [mm]	F vario [mm]	G [mm]	K [mm]	M stand [mm]	M vario [mm]	T [mm]	weight stand [kg/pc.]	Bolting Torque [Nm]	Ref.-No. Stand	Ref.-No. Vario with washer and nut
WWBG 6 (7.5) M33	6 (7.5)	22	86	50	90	-	33-300	94	80	-	33	208	-	350	-	8600150
VWBG 8 (10) M36	8 (10)	22	86	50	90	54	36-300	94	80	36	36-39	208	4.6	410	7999059	8600451
VWBG 12 (13) M42	12 (13)	26	111	65	98	63	42-300	96	85	42	42-45	235	6.1	550	7999044	8600452
VWBG 12 (15) M45	12 (15)	26	111	65	98	67	-	96	85	45	-	235	6.2	550	7900455	-
VWBG 13 (16) M48	13 (16)	26	111	65	98	68	48-300	96	85	48	48-52	235	6.3	550	7999045	8600453
VWBG 14 (20) M52	14 (20)	32	119	70	120	78	-	120	95	52	-	274	10.5	750	7901081	-
VWBG 16 (22) M56	16 (22)	32	119	70	120	84	56-300	120	95	56	56-62	274	10.7	800	7999004	8600454
VWBG 16 (25) M64	16 (25)	32	119	70	120	94	64-300	120	95	64	64-76	274	11.4	800	7999043	8600455
VWBG 31.5 (40) M72	31.5 (40)	46	130	90	170	108	72-300	159	145	72	72-76	338	29.9	1200	7900097	8600456
VWBG 35 (48) M80	35 (48)	46	130	90	170	120	80-300	159	145	80	80-85	338	31.2	1500	7900100	8600457
VWBG 40 (50) M90	40 (50)	46	170	110	170	135	90-300	159	145	90	90-150	378	34.5	2000	7903408	8600458

Table 2: Dimensioning (metric)

Type	WLL [t]	A [mm]	B [mm]	C [mm]	D [mm]	F [mm]	G [mm]	K [mm]	M [mm]	weight [kg/pc]	Bolting-torque [Nm]	Ref.-No. Stand.
VWBG 8 (10) - 1 1/2" - 6 UNC	8 (10)	22	86	50	90	57	94	80	1 1/2" - 6 UNC	4.8	410	8600451
VWBG 12 (13) - 1 3/4" - 5 UNC	12 (13)	26	111	65	98	66	95	85	1 3/4" - 5 UNC	6.2	550	8600452
VWBG 13 (16) - 2" - 4.5 UNC	13 (16)	26	111	65	98	76	95	85	2" - 4.5 UNC	6.2	550	8600453
VWBG 16 (22) - 2 1/4" - 4 UNC	16 (22)	32	119	70	120	85	120	95	2 1/4" - 4 UNC	11	800	8600454
VWBG 16 (25) - 2 3/4" - 4 UNC	16 (25)	32	119	70	120	104	120	95	2 3/4" - 4 UNC	12	800	8600455
VWBG 31.5 (40) - 3" - 4 UNC	31.5 (40)	46	130	90	170	114	159	145	3" - 4 UNC	26.3	1200	8600456
VWBG 35 (48) - 3 1/2" - 4 UNC	35 (48)	46	130	90	170	133	159	145	3 1/2" - 4 UNC	28	1500	8600457
VWBG 40 (50) - 4" - 4 UNC	40 (50)	46	168	110	170	150	159	145	4" - 4 UNC	36.7	2000	8600458

Table 3: Dimensioning (UNC)