

Lifting Point loadable from any side > B-ABA <



Safety instructions
This safety instruction/declaration has to be kept on file
for the whole lifetime of the product.
Translation of the original safety instruction



B-ABA



RUD Ketten
Rieger & Dietz GmbH u. Co. KG
73428 Aalen
Tel. +49 7361 504-1370
Fax +49 7361 504-1171
sling@rud.com
www.rud.com

RUD-Art.-Nr.: 7906416-EN / 11.018

EG-Konformitätserklärung

entsprechend der EG-Maschinenrichtlinie 2006/42/EG, Anhang II A und ihren Änderungen

Hersteller: **RUD Ketten
Rieger & Dietz GmbH u. Co. KG**
Friedensinsel
73432 Aalen

Hiermit erklären wir, dass die nachfolgend bezeichnete Maschine aufgrund ihrer Konzipierung und Bauart, sowie in der von uns in Verkehr gebrachten Ausführung, den grundlegenden Sicherheits- und Gesundheitsanforderungen der EG-Maschinenrichtlinie 2006/42/EG sowie den unten aufgeführten harmonisierten und nationalen Normen sowie technischen Spezifikationen entspricht.
Bei einer nicht mit uns abgestimmten Änderung der Maschine verliert diese Erklärung ihre Gültigkeit.

Produktbezeichnung: Anschraubpunkt starr
B-ABA

Folgende harmonisierten Normen wurden angewandt:

<u>DIN EN 1677-1 : 2009-03</u>	<u>DIN EN ISO 12100 : 2011-03</u>
_____	_____
_____	_____

Folgende nationalen Normen und technische Spezifikationen wurden außerdem angewandt:

<u>BGR 500, KAP2.8 : 2008-04</u>	_____
_____	_____
_____	_____

Für die Zusammenstellung der Konformitätsdokumentation bevollmächtigte Person:
Michael Betzler, RUD Ketten, 73432 Aalen

Aalen, den 22.09.2016 Dr.-Ing. Arne Kriegsmann, (Prokurist/QMB)
Name, Funktion und Unterschrift Verantwortlicher *Arne Kriegsmann*

EC-Declaration of conformity

According to the EC-Machinery Directive 2006/42/EC, annex II A and amendments

Manufacturer: **RUD Ketten
Rieger & Dietz GmbH u. Co. KG**
Friedensinsel
73432 Aalen

We hereby declare that the equipment sold by us because of its design and construction, as mentioned below, corresponds to the appropriate, basic requirements of safety and health of the corresponding EC-Machinery Directive 2006/42/EC as well as to the below mentioned harmonized and national norms as well as technical specifications.
In case of any modification of the equipment, not being agreed upon with us, this declaration becomes invalid.

Product name: Lifting point rigid
B-ABA

The following harmonized norms were applied:

<u>DIN EN 1677-1 : 2009-03</u>	<u>DIN EN ISO 12100 : 2011-03</u>
_____	_____
_____	_____

The following national norms and technical specifications were applied:

<u>BGR 500, KAP2.8 : 2008-04</u>	_____
_____	_____
_____	_____

Authorized person for the configuration of the declaration documents:
Michael Betzler, RUD Ketten, 73432 Aalen

Aalen, den 22.09.2016 Dr.-Ing. Arne Kriegsmann, (Prokurist/QMB)
Name, function and signature of the responsible person *Arne Kriegsmann*



Before initial usage of the RUD lifting point B-ABA, please read carefully the safety instructions. Make sure that you have understood all subjected matters. Non-observance can lead to serious personal injuries and material damage and eliminates warranty.

1 Safety instructions



ATTENTION

Wrong assembled or damaged lifting points B-ABA as well as improper use can lead to injuries of persons and damage of objects when load drops. Please inspect all lifting points before each use.

- RUD lifting points B-ABA must only be used by instructed and competent persons considering BGR 500 (DGUV-rules 100-500) and outside Germany noticing the country specific statutory regulations.

2 Intended use of the B-ABA

RUD lifting points B-ABA must only be used for the assembly at the load or at lifting means.

They are intended to be hinged into lifting means.

RUD lifting points B-ABA can also be used as lashing points to attach lashing means.

Loading from any side is permitted.

RUD lifting points B-ABA must only be used in the hereby described operation purpose.

3 Assembly- and instruction manual

3.1 General information

- Capability of temperature usage:
When used at higher temperatures the working load limit (WLL) of the lifting point must be reduced as follows:

- 40°C up to 200°C no reduction
- 200°C up to 300°C minus 10 %
- 300°C up to 400°C minus 25 %

Temperatures exceeding 400°C are prohibited!

- RUD lifting points B-ABA must not be used with aggressive chemicals such as acids, alkaline solutions and their vapours.
- Please mark mounting position of lifting point with a coloured contrast paint for better visibility.

3.2 Hints for the assembly

Basically essential:

- The material construction to which the lifting point will be attached should be of adequate strength to withstand forces during lifting without deformation. The German testing authority BG/DGUV, recommends the following minimum for bolt lengths:
 - 1x M in steel (minimum quality S235JR[1.0037])
 - 1.25x M in cast iron (however when castings of lower strength [<200 MPa] are used the thread engagement has to be at least $1,5x d$)
 - 2x M in aluminum alloys
 - 2.5x M in light metals of low strength (M = thread size, e.g. M20)
- The position of the lifting points must be carried out in such a way that unintended movement like turning or flipping will be avoided:
 - For single leg lifts:** the lifting point should be vertically above the centre of gravity of the load.
 - For two leg lifts:** the lifting points must be equidistant to/or above the centre of gravity of the load.
 - For three and four leg lifts.** the lifting points should be arranged symmetrical around the centre of gravity, in the same plane if possible.
- Symmetry of loading:
Determine the necessary WLL of each lifting point for a symmetrical or an unsymmetrical load by using the following physical calculation formula:

$$W_{LL} = \frac{G}{n \times \cos \beta}$$

W_{LL} = necessary WLL (kg) of lifting point / single strand (kg)
 G = weight of load (kg)
 n = number of load bearing strands
 β = Inclination angle of single strand

Number of load bearing strands:

	symmetric	unsymmetric
two leg	2	1
three / four leg	3	1

Table 1: Load bearing strands (compare to table 3)

- RUD lifting points B-ABA must be installed by using the supplied ICE-bolts. If needed, Vario-ICE-bolts can be ordered on request (compare chart 5 / pic. 4).
- A plane bolt-on surface must be ensured resp. provided. Blind holes must be drilled deep enough, that the supporting area of the B-ABA fits properly. Tighten bolts with required torque value (see table 2).
- For a single use hand tightening with a spanner is sufficient. Bolt supporting area must sit proper on bolt-on surface.
- Check finally the correct assembly (see chapter 4, Inspection criteria).

3.3 User instructions

- Check frequently and before each initial operation the whole lifting point B-ABA in regard of lingers ability as a lifting mean, regarding corrosion, wear, deformation etc. (see chapter 4, *Inspection criteria*).



ATTENTION

Wrong positioned or damaged lifting points as well as improper use can lead to injuries of persons and damage at property, when load falls down. Please check all lifting points carefully before every usage.

- Please check carefully the wear indicator markings of the weld-on lifting point (see picture 4):



Usage permitted:
no wear marks visible

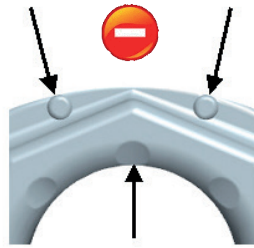

Use prohibited:
Replacement criteria reached. Material all the way down to the wear lenses has gone

Pic. 1: Wear indicators

- To prevent unintended dismounting through shock loading, rotation or vibration, thread locking fluid such as Loctite (depending on the application, please pay attention to the manufacturer's instruction) could be used to secure the bolt, or use form-closed devices.
- Please note that the lifting mean must be free moveable within the lifting point B-ABA. When lifting means (sling chains) are hinged or unhinged, no pinching, shearing or joint spots must occur during the handling.
- Avoid damage of lifting means resulting from sharp edges.
- If the lifting point B-ABA is used solely for lashing, the value of the working load limit can be doubled: $LC = 2 \times WLL$

3.5 Hints for regular inspection

In time periods complying to the need or usage, a technical expert must control at least once per year the appropriateness of the lifting point. This inspection must also be done after each event of damage or special incident.

4 Inspection criteria

Observe and control the following points before each initial operation, in regular time intervals, after the assembly and after special incidents:

- Completeness of the lifting point
- Complete, readable WLL statements as well as manufacturer sign
- Deformation at load bearing components like base body and bolts
- Mechanical damage, like strong notches, especially in areas where tensile stress occurs
- Reduction of cross-section due to wear >10 % (see picture 1, wear indicators)
- Evidence of corrosion (Pitting)
- Cracks at the weld seam
- Ensure correct bolt and nut size, quality and length.
- Ensure compatibility of bolt thread and tapped hole
- Function and damage at the bolt, nut and/or thread.

Type	torque [Nm]	thread d	wrench size SW
B-ABA 1.6 t	55	M10	16
B-ABA 3.2 t	100	M12	18
B-ABA 5 t	240	M16	24
B-ABA 10 t	450	M20	30
B-ABA 20 t	800	M24	36
B-ABA 31.5 t	950	M30	46

Table 2

Method of lift										
number of legs	1	1	2	2	2	2	2	3/4	3/4	3/4
Angle of inclination	0°	90°	0°	90°	0-45°	45°-60°	Unsymm.	0-45°	45°-60°	Unsymm.
Factor	1	1	2	2	1.4	1	1	2.1	1.5	1
Type	For the max. total load weight >G< in metric tons [t]									
B-ABA 1.6 t	1.6	1.6	3.2	3.2	2.2	1.6	1.6	3.4	2.4	1.6
B-ABA 3.2 t	3.2	3.2	6.4	6.4	4.5	3.2	3.2	6.8	4.8	3.2
B-ABA 5 t	5,0	5,0	10	10	7.1	5	5	10.6	7.5	5
B-ABA 10 t	10,0	10,0	20	20	14.1	10	10	21.2	15	10
B-ABA 20 t	20,0	20,0	40	40	28	20	20	42	30	20
B-ABA 31.5 t	31.5	31.5	63	63	45	31.5	31.5	67	47.5	31.5

Table 3: WLL in [t]

Type	WLL Lifting [t]	A [mm]	B [mm]	C [mm]	D [mm]	E [mm]	F [mm]	G [mm]	H [mm]	T [mm]	L [mm]	M	weight [kg/pc.]	Ref.-No.
B-ABA 1.6 t	1.6	75	16	100	35	16	62.5	55	55	46.5	13	4 x M10	0.9	7906266
B-ABA 3.2 t	3.2	92	23	137	50	21	86	70	75	65	16	4 x M12	2.0	7906267
B-ABA 5 t	5.0	113	27	172	60	28	108	84	95	80	24	4 x M16	4.1	7906268
B-ABA 10 t	10.0	146	38	228	80	36	141	110	125	105	25	4 x M20	9.3	7906269
B-ABA 20 t	20.0	200	52	272	115	40	188	150	75	148	30	6x M24	18.8	7906270
B-ABA 31.5 t	31.5	230	64	320	130	50	215	175	87.5	165	40	6x M30	29.5	7906271

Table 4: Dimensioning

Subject to technical alterations

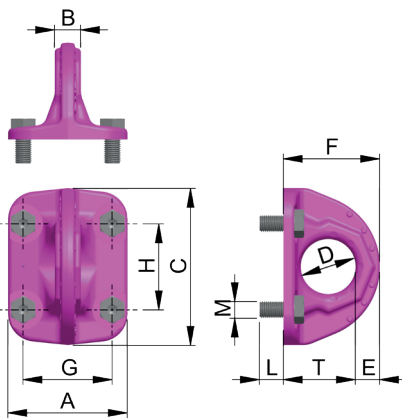

Pic. 2: Dimensioning B-ABA 1.6 t - 10 t

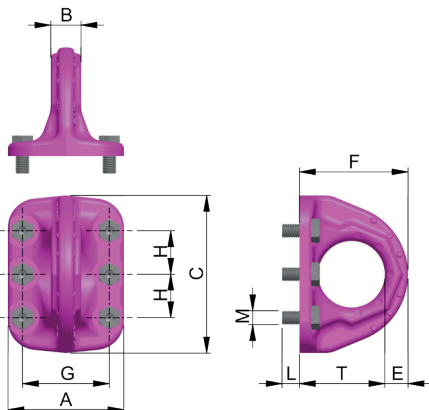

Pic. 3: Dimensioning B-ABA 20 t - 31.5 t

Type	K [mm]	L _{max} [mm]	M	used bolt	Ref.-No. ICE-bolt
B-ABA 1.6 t	125	118	4 x M10	M10 x 125	7905920
B-ABA 3.2 t	145	136	4 x M12	M12 x 145	7905921
B-ABA 5 t	185	174	4 x M16	M16 x 185	7908216
B-ABA 10 t	230	215	4 x M20	M20 x 230	7908217
B-ABA 20 t	265	245	6 x M24	M24 x 265	7908218
B-ABA 31.5 t	340	320	6 x M30	M30 x 340	7908418

Table 5: Vario-ICE-bolts (thread all the way up to the head)

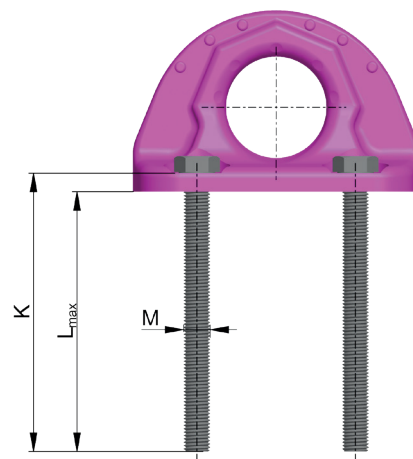

Pic. 4: B-ABA bolt length