

Type PHA2000 Automatic Pallet Hook

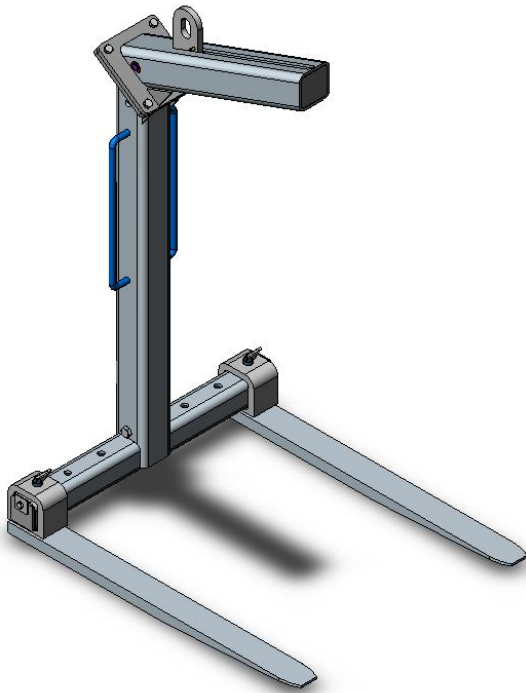

The type PHA2000 Automatic Pallet Hook has been designed to handle palletted goods safely when being lifted by overhead crane. The unit self balances when loaded for ease of operation with an internal spring mechanism ensuring the lifting eye is in the correct position to maintain the Fork Tines horizontally. This eliminates the need to balance the Pallet Hook manually as on the 'PHD2200' model. The robust high tensile steel lightweight construction delivers maximum strength with zero maintenance and ease of use. Fork Tine width is adjustable to 315, 595 or 875mm centres. The standard finish on the Pallet Hook is Zinc Plated.

The Pallet Hook has been designed & certified in accordance with Australian Standard AS 1418.1.

SPECIFICATIONS:

- Safe Working Load (SWL) 2000kg
- Load Centre 600mm
- Unit Weight 196kg

